

PORTA-FAB

Cleanroom Wall Systems

FABLINE FURRING 500

INSTALLATION INSTRUCTIONS

IMPORTANT

Porta-Fab Advises A Thorough Reading of These Instructions Before Beginning Installation.

INTRODUCTION

Porta-Fab has fabricated this FabLine Furring 500 Cleanroom Wall System with superior materials. Even though these materials were packaged with care, damage may have occurred during transit. Please inspect this shipment for damage and quantity before beginning installation. Please notify us promptly if you experience any problems at (800) 325-3781.

CONTENTS

Uncrating, Inspection, and Inventory	3
FabLine Extrusion Guide	4
Installation of Floor Track.....	5
Floor Track at Corners	5
Installation of Panels.....	6
Panel Dimensions for Various Wall Conditions	7
Installation of Head Track.....	7
Head Track at Corners	8
Trimming Around Existing Doors, Windows and Openings.....	8
Installation of Corners.....	9
Installation of Wall Starters.....	10
Installation of Panel Connectors	10
Final Inspection and Wipe Down	11

TOOLS

We suggest the following tools to erect this system:

- Soft Rubber Mallet
- Claw Hammer
- Suction Cup Panel Holders
- Long Blade Putty Knife
- Circular Saw with Fine Toothed Carbide Tip Blade (triple toothed, negative rake, aluminum blade)
- Miter Saw with Fine Toothed Carbide Tip Blade (triple toothed, negative rake, aluminum blade)
- Plunge Router with Four Toothed Fluted Carbide Tip Blade or Saw Zaw with 32 toothed per inch blade

The following information is provided by Porta-Fab Corporation as a general guideline for the installation of the Furring 500 modular cleanroom wall systems. This information should be reviewed prior to commencing installation. The intent is to be as specific as possible in detail for a typical project, yet general enough to be utilized by most installation teams. It is Porta-Fab's hope that the descriptions are helpful and as easy to understand as the wall system itself. Of course, if there are any questions, comments, or special considerations, please contact Porta-Fab.

This narrative assumes that the job-site is clear and ready for the construction of cleanroom walls. The ceiling grid and the access floor, if applicable, are to be in place prior to beginning work on the walls.

Uncrating, Inspection, and Inventory

The Porta-Fab wall system is packaged in the factory in a manner to protect each part during normal shipping and handling. It is recommended by Porta-Fab that the original packaging remain intact as much as possible until the individual parts are needed. All extrusion components are typically packaged in boxes and between styrofoam packaging. Panels are shipped with a protective plastic film, which should be left on the panels until the installation is complete and ready for final wipe-down.

As the crates are received at the job-site, they should be placed in a location near the installation area, where they will not become an obstacle, or require to be moved at a later time. The crates should then be opened, however leaving the internal packaging unchanged. Pieces can be removed on an as needed basis and the packaging discarded then. At this time, however, the components should be visually inspected for obvious damage and an inventory taken to confirm that all parts are received as expected. Notify Porta-Fab immediately of any discrepancies.

Fasteners Not Provided By Porta-Fab

Porta-Fab does not provide the attachment hardware for the existing structure or framework, due to installer preferences and local codes, the type of hardware shall not be discussed here. When determining hardware needs, know that the track of the extrusions has an opening of ½" with slotted openings every 6" on center, which a fastener must pass through. The extrusions are pre-punched 6" on center with ¼" diameter by ½" long slots. For most installations, attachment to the existing structure or framework at approximately 12" on center is recommended.

FabLine Extrusion Guide

Part #

Description

Detail

FABAEANCVRF5

Panel Connector



FABAEANTBE5

Top/Bottom/End Trim

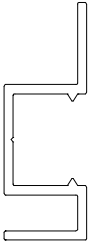

FABAEANOCF5

Outside Corner Trim

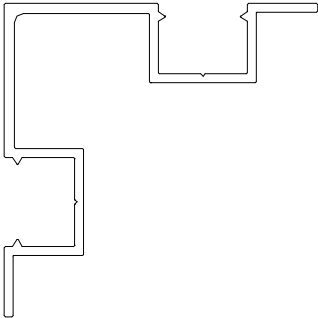

FABAEANICF5

Inside Corner Trim

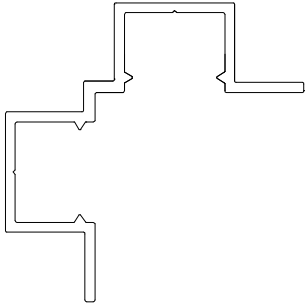

FABVEFCS

Furring Cover Strip

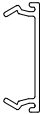

Installation of Floor Track

The first component to be installed is the floor track (FABAEANTBE5). Install the 1/16" x 1 5/8" neoprene gasket (FABGSKNEO1/16), if required, on the existing wall or framework behind where the floor track will be mounted prior to mounting the floor track. The floor track is to be installed above the floor as per the layout of the particular project.

Basically, the floor track is to be laid at all areas except at existing door openings, framed openings, and equipment bulkheads.

When installing the floor track, it is recommended that the floor track not be fastened tight against the existing surface leaving some tolerance for the insertion of the wall panel which follows the floor track installation.

Once the panels have been installed and the floor track secured tightly to the existing wall or framework, install the furring cover strips (FABVEFCS) into the floor track.

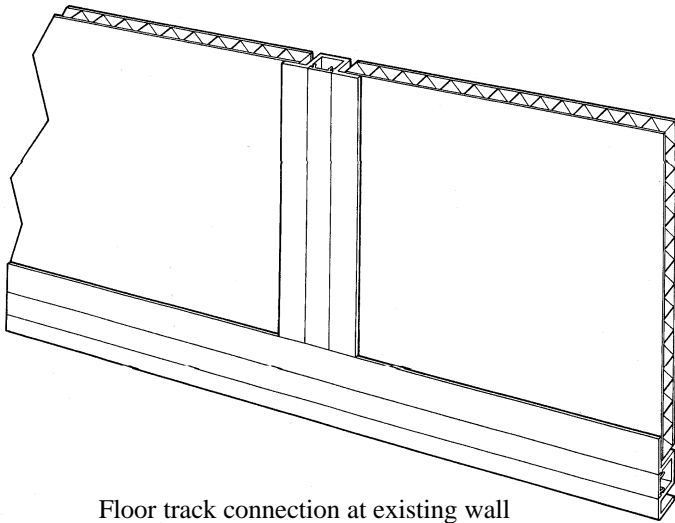
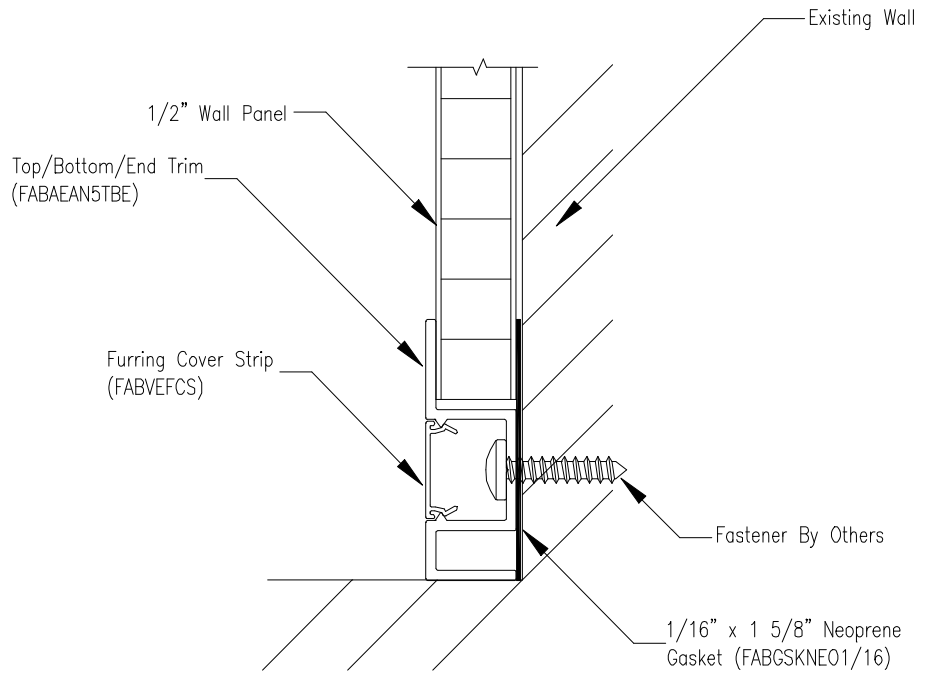

Floor track connection at existing wall

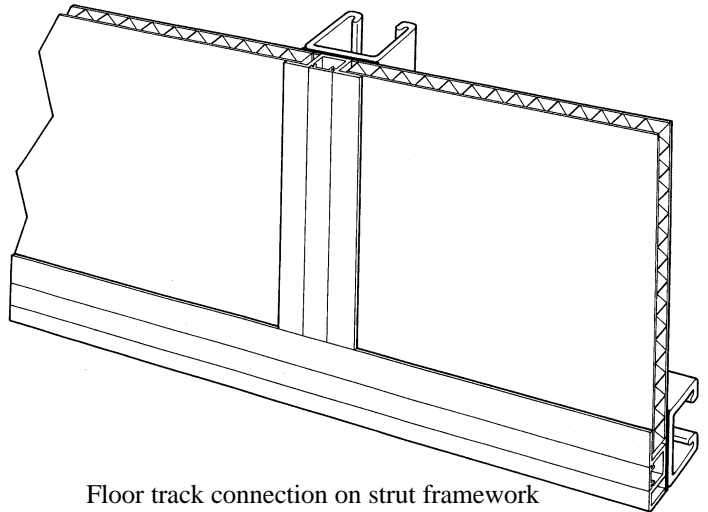

Floor track connection on strut framework

Floor Track at Corners

The floor track (FABAEANTBE5) is to be miter cut at 45° in the field by the installation team to create corners.

Installation of Panels

Before installing a panel, peel back the protective film on both surfaces of the panel around all four edges. By leaving the majority of the film in place until final clean-up, there is extra protection against damage to the panels. If the height of the wall panel needs to be modified, subtract 2 ¼" from the inside floor to ceiling (e.g. 120" floor to ceiling clear height – panel height should be 117 ¾" tall).

First, install the 1/16" x 1 5/8" neoprene gasket (FABGSKNEO1/16), if required, on the existing wall or framework behind where the panel connectors, corner trims and wall starters will be mounted between the wall panels. The wall panels will overlap onto the neoprene gasket slightly to create a seal between the back of the panel and the cleanroom. Next, install the wall panel by lifting it over the floor track and inserting it down into the floor track. Again, the fasteners in the floor track should be loose enough to allow the wall panel to fit between the floor track and the existing wall or framework. Panels are typically installed on the same gridlines as the cleanroom ceiling grid overhead or access floor below, which can act as a guide during installation. The vertical strip of neoprene gasket where the panel connector will install can also assist with this process. A gap of 7/8" is to be left between panels, which will be filled by the panel connector. To assist, cut a six-inch section of the panel connector to temporarily secure the wall panels in place and help in lining up with the grid and flooring.

After installing the wall panels through one section of floor track, proceed to completely secure the floor track to the existing wall or framework.

Panels at the end of a straight run may require to be cut down to width. In these instances, please refer to the panel dimension chart for correct panel widths from various extrusion connections. Mark and cut the panel with a circular saw while the plastic protective film remains intact.

PANEL DIMENSIONS FOR VARIOUS WALL CONDITIONS

DIMENSIONS SHOWN INCLUDE THE STANDARD 47 1/8" WIDE PANEL

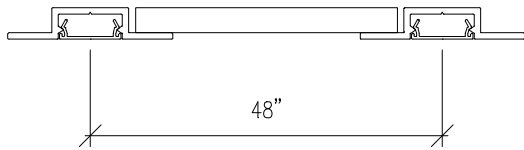

PANEL WIDTH = C TO C DIMENSION LESS 7/8"

COVER TO COVER

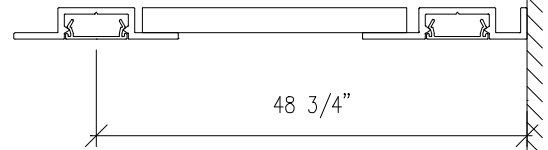

PANEL WIDTH = C TO WALL
DIMENSION LESS 1 5/8"

WALL START TO COVER

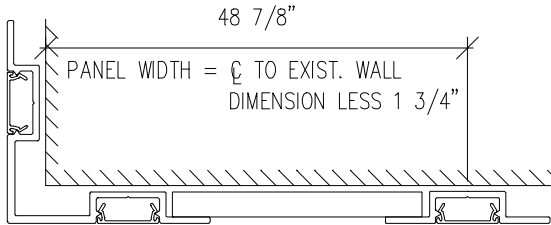

PANEL WIDTH = C TO EXIST. WALL
DIMENSION LESS 1 3/4"

OUTSIDE CORNER TO COVER

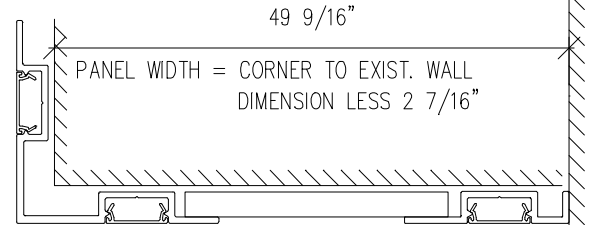

PANEL WIDTH = CORNER TO EXIST. WALL
DIMENSION LESS 2 7/16"

OUTSIDE CORNER TO WALL START

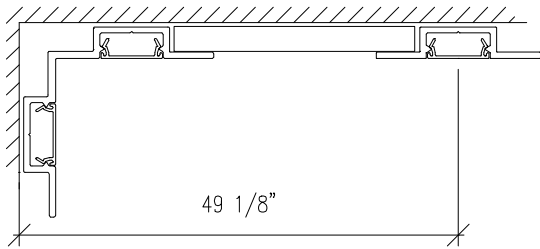

PANEL WIDTH = C TO EXIST. WALL
DIMENSION LESS 1 3/4"

INSIDE CORNER TO COVER

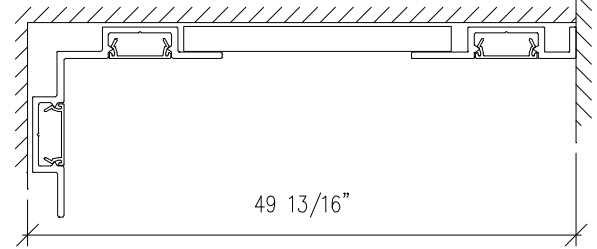

PANEL WIDTH = CORNER TO EXIST. WALL
DIMENSION LESS 2 7/16"

INSIDE CORNER TO WALL START

Installation of Head Track

After the floor track and wall panels are installed, the head track (FABAEANTBE5) is to be secured to the top of the existing wall or framework. Install the 1/16" x 1 5/8" neoprene gasket (FABGSKNEO1/16), if required, on the existing wall or framework behind where the head track will be mounted prior to mounting the head track. The head track is to be installed directly beneath the ceiling grid as per the layout of the particular project. Finally, install the furring cover strips (FABVEFCS) into the head track.

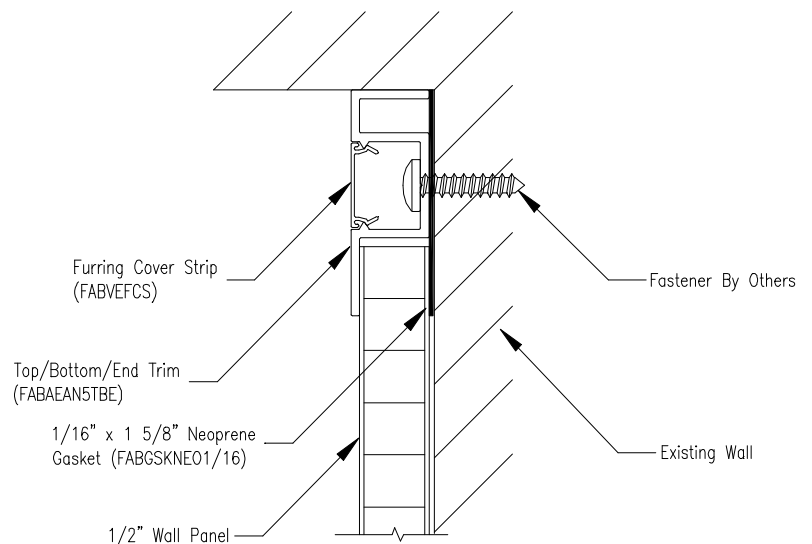

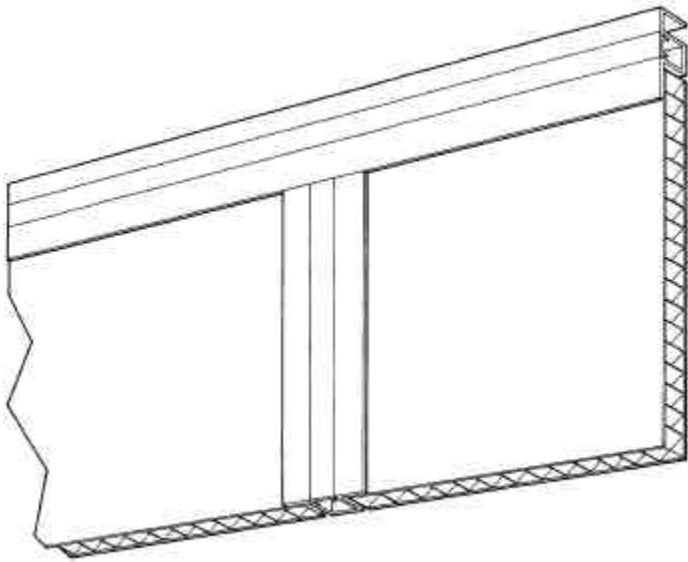

Head track connection at existing wall

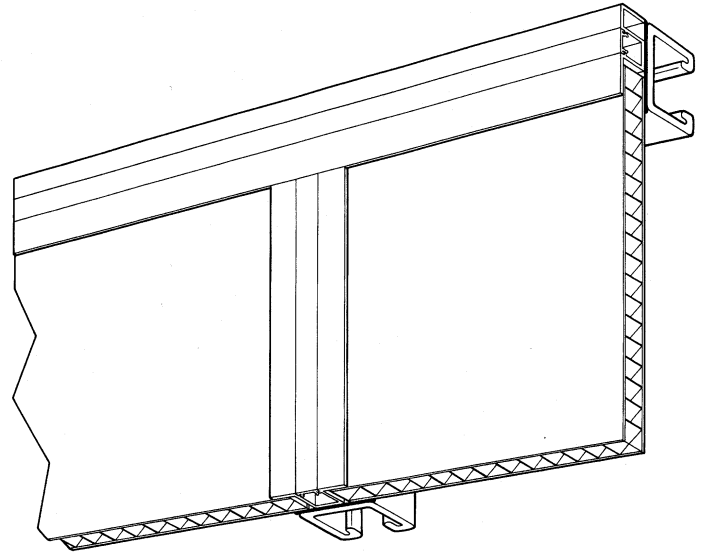

Head track connection on strut framework

Head Track at Corners

The head track (FABAEANTBE5) is to be miter cut at 45° in the field by the installation team to create corners.

Trimming Around Existing Doors, Windows, and Openings

An existing opening in the wall can be easily trimmed around to provide a finished appearance. At existing doors or windows where a steel frame is utilized, install the 1/16" x 1 5/8" neoprene gasket, (FABGSKNEO1/16), if required, on the existing wall or framework around all the edges of the opening which will be finished off. This is done prior to installing the end cap trim. Wall panels should be cut to the size and/or configuration required to trim around the opening. Mount panel in place and attach end cap trims with the finished edge side to the existing frame. Finally, install the furring cover strips (FABVEFCS) into the (FABAEANTBES) end cap trims.

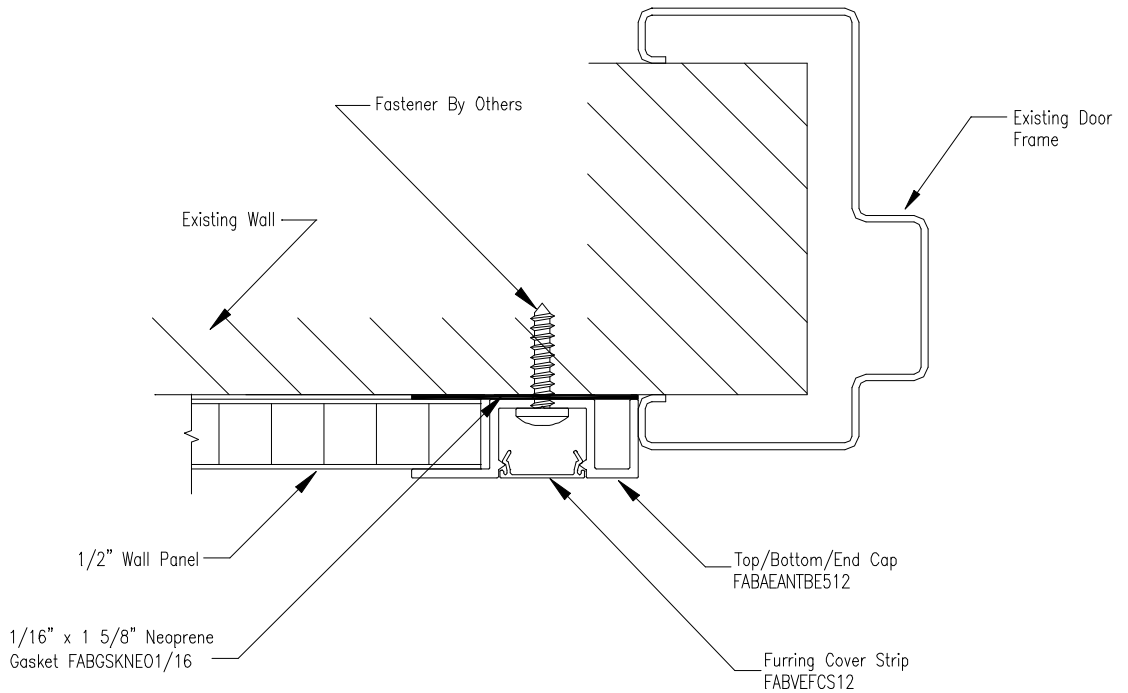

Finally, install the furring cover strips (FABVEFCS) into the (FABAEANTBES) end cap trims.

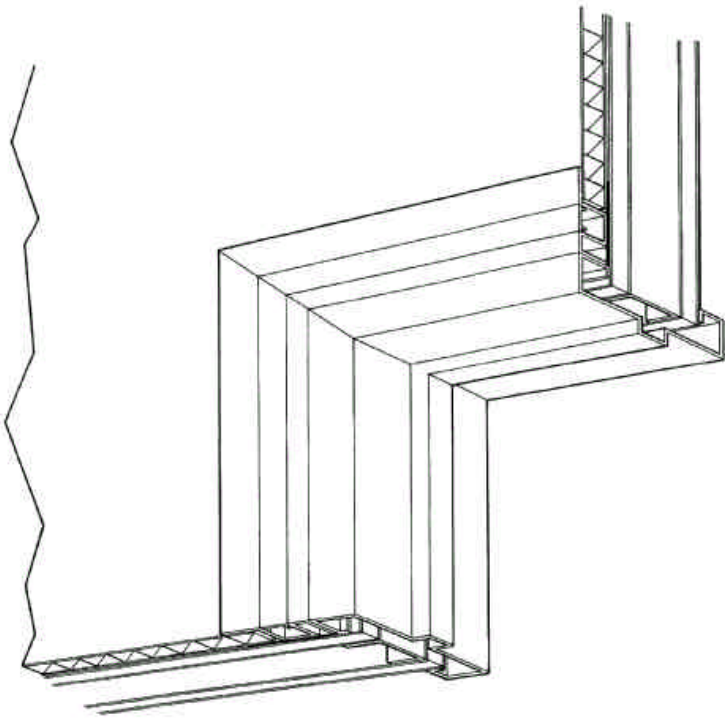

End cap at existing door frame

Installation of Corners

The corner trim is ready to install after the head track, floor track and panels are in place. There are two corner trim extrusions: an outside corner trim and an inside corner trim. First, measure the distance from the bottom of the floor track to the top of the head track. The corner trim to be utilized should be cut to 3 1/4" less than the measured length between the floor track and head track. This will allow the top and the bottom of the corner trim to be flush and tight against the upper edge of the floor track and lower edge of the head track. Now install the 1/16" x 1 5/8" neoprene gasket (FABGSKNEO1/16), if required, on the existing wall or framework behind where the corner trim will be mounted prior to mounting the corner trim. The corner trim will require two separate rows of gasket. Next, install the corner

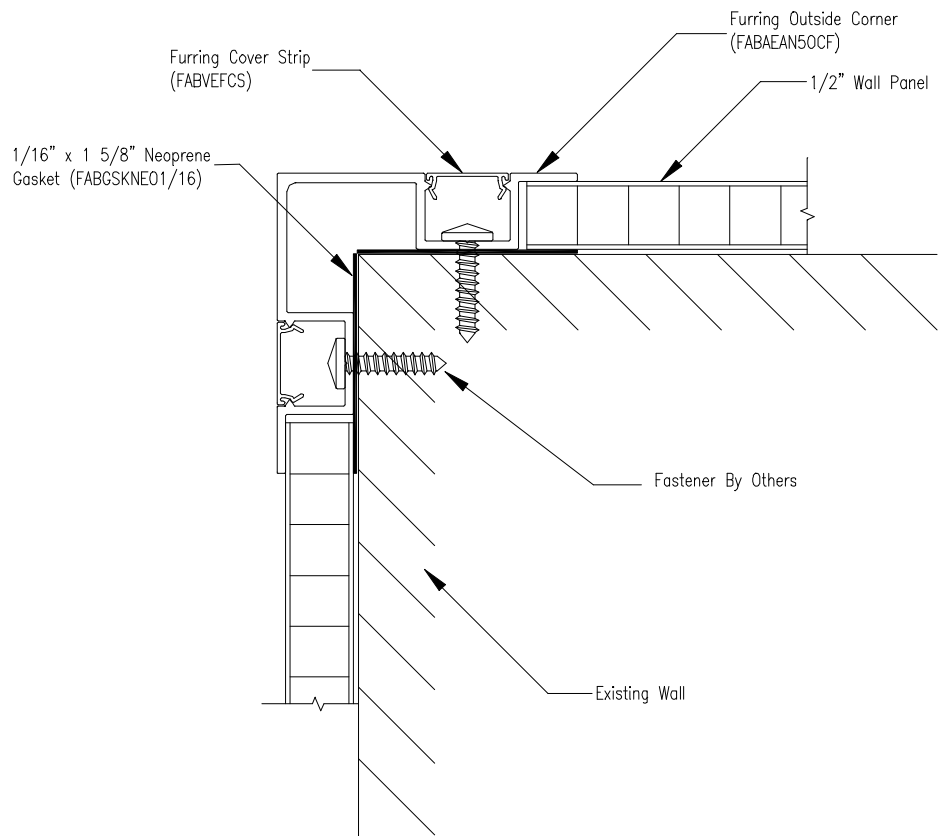

trim, by inserting the component between the head track and floor track and between two panels. Be certain that the top and the bottom of the corner trim is flush and tight against the upper edge of the floor track and lower edge of the head track.

Fasten the corner trim to the existing structure or framework. Install the furring cover strip (FABVEFCS) into the corner trim. Repeat this operation on the second leg of the corner trim.

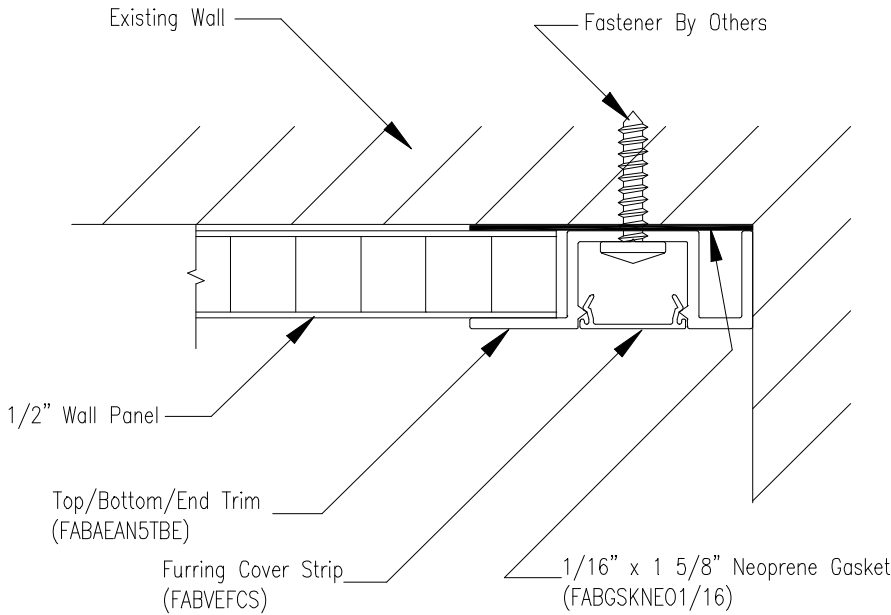

gasket (FABGSKNEO1/16), if required, on the existing wall or framework behind where the wall starter will be mounted prior to mounting the wall starter. Next, install the wall starter, by inserting the component between the head track and floor track. Be certain that the top and the bottom of the wall starter is flush and tight against the upper edge of the floor track and lower edge of the head track.

Fasten the wall starter to the existing structure or framework. Install the furring cover strip (FABVEFCS) into the wall starter.

Installation of Wall Starters

A wall starter is defined as an abutment of the Porta-Fab wall system to any other surface, such as an existing wall by others.

First, measure the distance from the bottom of the floor track to the top of the head track. The wall starter (FABAEANTBE5) to be utilized should be cut to 3 1/4" less than the measured length between the floor track and head track. This will allow the top and the bottom of the wall starter to be flush and tight against the upper edge of the floor track and lower edge of the head track. Now install the 1/16" x 1 5/8" neoprene

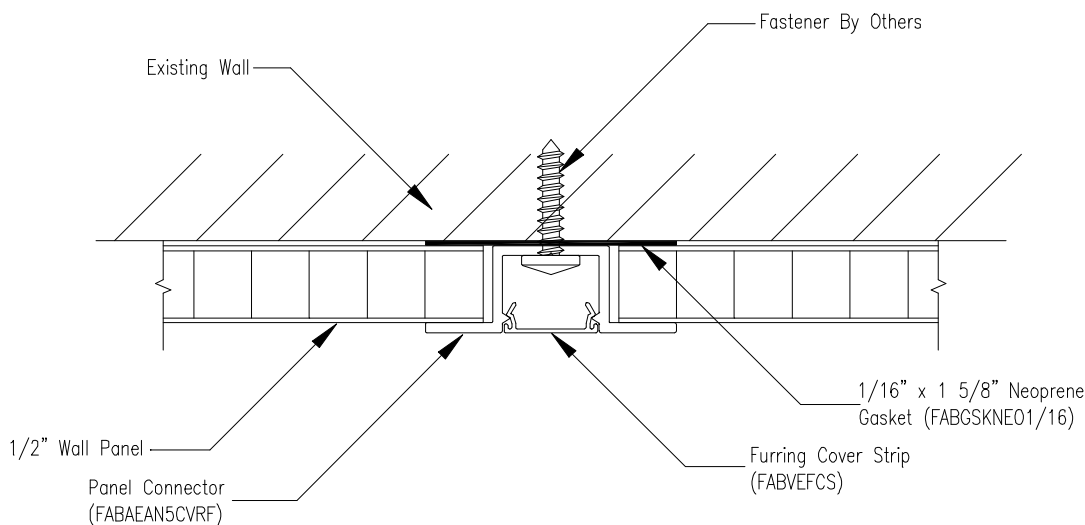

Installation of Panel Connectors

The gap between the panels is to be closed off with the panel connector (FABAEANCVRF5), which also ties the panels together creating a rigid wall system. First, measure the distance from the bottom of the floor track to the top of the head track. The panel connector (FABAEANCVRF5) to

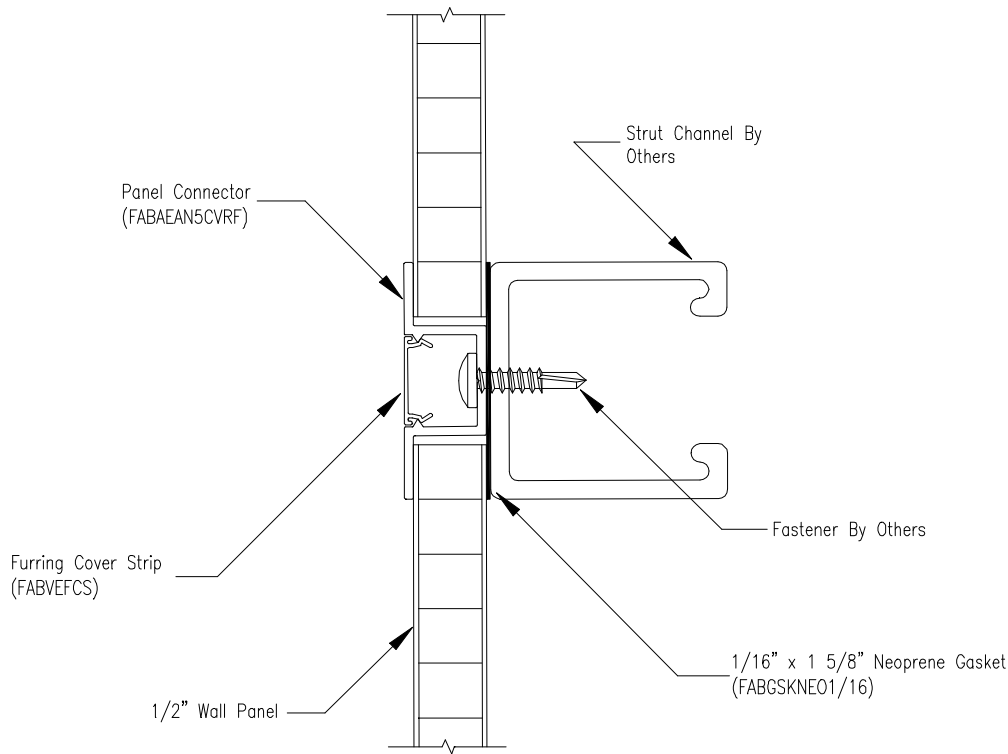

be utilized should be cut to 3 1/4" less than the measured length between the floor track and head track. This will allow the top and the bottom of the panel connector to be flush and tight against the upper edge of the floor track and lower edge of the head track. Next, install the panel connector, by inserting the component between the head track and floor track and between two panels. Be certain that the top and the bottom of the panel connector is flush and tight against the upper edge of the floor track and lower edge of the head track.

Fasten the panel connector to the existing structure or framework. Install the furring cover strip (FABVEFCS) into the panel connector.

Final Inspection and Wipe Down

Prior to completing the installation, a final inspection and wipe-down should take place. First, remove the plastic protective film from the panels by pulling them off. It may be desirable to leave the plastic film in place until after equipment is placed in the room, to provide added protection to the panels.

Wipe the panels and extrusions with an approved cleanroom alcohol wipe. If any chemicals are to be utilized, spot check with extra materials prior to use to insure that the finish of the wall system is not damaged.