

# **PORTA-FAB**

## **Cleanroom Wall Systems**

### **FABLINE BATTEN 2000**

### **INSTALLATION INSTRUCTIONS**



#### **IMPORTANT**

**Porta-Fab Advises A Thorough Reading of These Instructions Before Beginning Installation.**

## INTRODUCTION

Porta-Fab has fabricated this FabLine Batten 2000 Cleanroom Wall System with superior materials. Even though these materials were packaged with care, damage may have occurred during transit. Please inspect this shipment for damage and quantity before beginning installation. Please notify us promptly if you experience any problems at (800) 325-3781.

## CONTENTS

Uncrating, Inspection, and Inventory .....	3
FabLine Extrusion Guide .....	4
FabLine Hardware Guide .....	6
Installation of Head Track .....	7
Head Track at Corners .....	7
Installation of Floor Track .....	7
Floor Track at Corners .....	8
Floor Track at Door Openings .....	8
Floor Track at Wall Ends and Framed Openings .....	9
Installation of Corners .....	9
Installation of Wall Starters .....	11
Installation of Wall End Caps .....	11
Installation of Panels and Preglazed Panels .....	12
Panel Dimensions for Various Wall Conditions .....	13
Installation of Batten Stud Posts .....	13
Installation of T-Intersections .....	15
Final Inspection and Wipe Down .....	16

We suggest the following tools to erect this system:

- Torx Head Wrench: T-27 Torx with Magnetic Tip
- Soft Rubber Mallet
- Claw Hammer
- Suction Cup Panel Holders
- Long Blade Putty Knife
- Circular Saw with Fine Toothed Carbide Tip Blade (triple toothed, negative rake, aluminum blade)
- Miter Saw with Fine Toothed Carbide Tip Blade (triple toothed, negative rake, aluminum blade)
- Plunge Router with Four Toothed Fluted Carbide Tip Blade or Saw Zaw with 32 toothed per inch blade

The following information is provided by Porta-Fab Corporation as a general guideline for the installation of the Batten 2000 modular cleanroom wall systems. This information should be reviewed prior to commencing installation. The intent is to be as specific as possible in detail for a typical project, yet general enough to be utilized by most installation teams. It is Porta-Fab's hope that the descriptions are helpful and as easy to understand as the wall system itself. Of course, if there are any questions, comments, or special considerations, please contact Porta-Fab.

This narrative assumes that the job-site is clear and ready for the construction of cleanroom walls. The ceiling grid and the access floor, if applicable, are to be in place prior to beginning work on the walls.

### **Uncrating, Inspection, and Inventory**

The Porta-Fab wall system is packaged in the factory in a manner to protect each part during normal shipping and handling. It is recommended by Porta-Fab that the original packaging remain intact as much as possible until the individual parts are needed. All extrusion components are typically packaged in boxes and between styrofoam packaging. Panels are shipped with a protective plastic film, which should be left on the panels until the installation is complete and ready for final wipe-down.

As the crates are received at the job-site, they should be placed in a location near the installation area, where they will not become an obstacle, or require to be moved at a later time. The crates should then be opened, however; leaving the internal packaging unchanged. Pieces can be removed on an as needed basis and the packaging discarded then. At this time, the components should be visually inspected for obvious damage and an inventory taken to confirm that all parts are received as expected. Notify Porta-Fab immediately of any discrepancies.

### **Fasteners Not Provided By Porta-Fab**

The attachment hardware for the flooring, ceiling, and wall starters to existing structures are not included by Porta-Fab due to installer preferences, local codes, and varying flooring and ceiling systems.

Typically, the floor track/wall starter attachment will be a screw into an access floor panel or existing wall, a "J" hook to attach to a grate type access floor, or a concrete anchor. The track in the bottom of the floor track is 5/8" wide. The floor track is pre-punched 6" on center with .266" diameter holes.

The track at the top of the head track has an opening of 5/8" with slotted openings every 6" on center, which a bolt head must pass through. The head track is pre-punched 6" on center with .20" diameter by .50" long slots. For most installations, attachment to the ceiling grid at approximately 24" on center is recommended.

# FabLine Extrusion Guide

**Part #**

**Description**

**Detail**

FABAEANCVR

Batten/Stud Cover

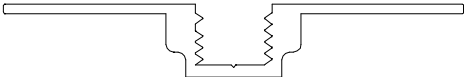

FABAEANBWC

Half Batten Cover

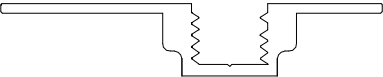

FABAEANBSP

Batten Stud Post

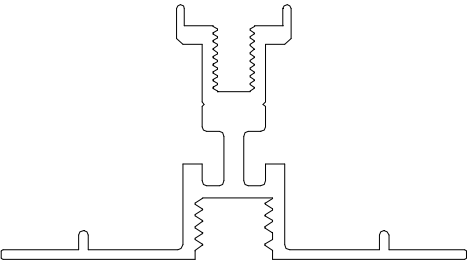

FABAEANFSP

Framed Stud Post

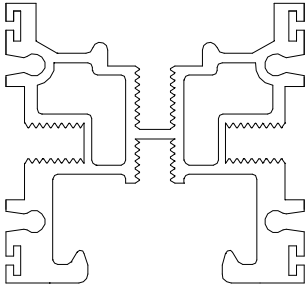

FABAEANWEC

Wall End Cap



FABAEANFT

Floor Track/Wall Starter

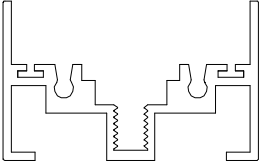

FABAEANHT

Head Track

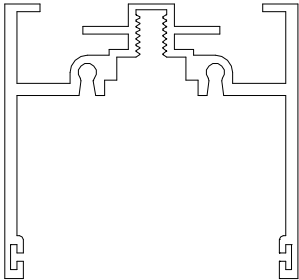

# FabLine Extrusion Guide

**Part #**

**Description**

**Detail**

FABAEANWS

Tee Intersection

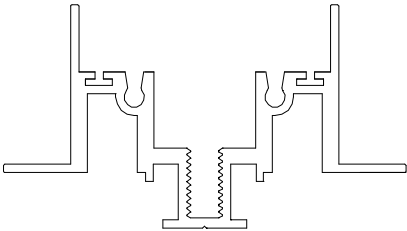

FABAEANBCP

Batten Corner Post

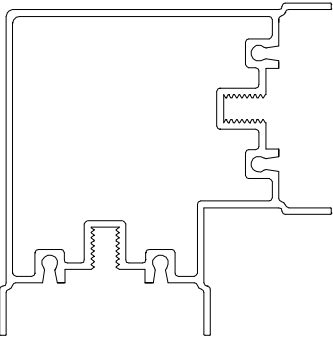

FABAEANFCP

Framed Corner Post

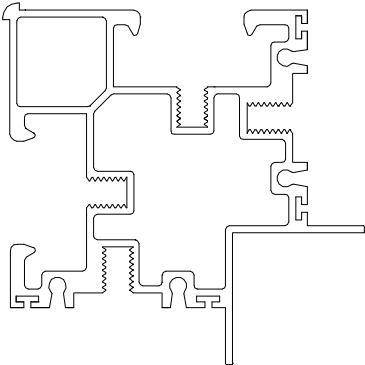

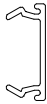

FABVEBCS

Batten Cover Strip

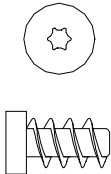
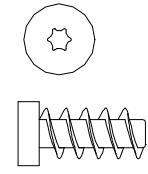
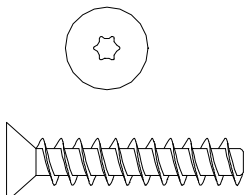
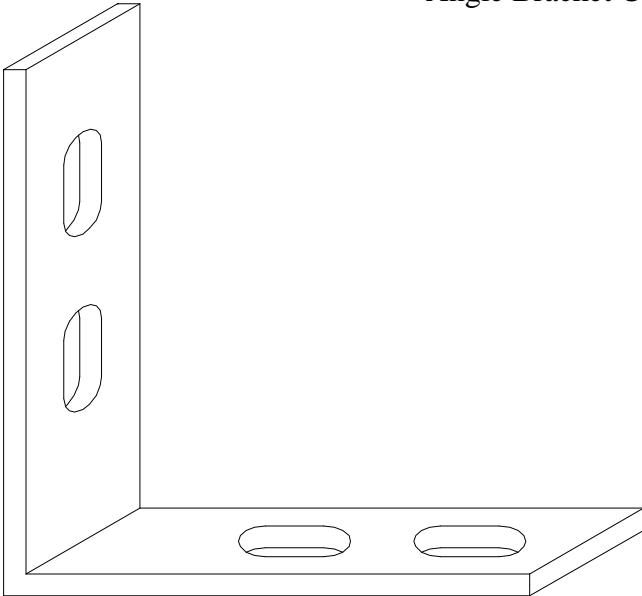

## FABLINE HARDWARE GUIDE

Part #	Sample	Description	Uses
FABFAS500T		<p>1/4"-20x1/2" Low Head Socket Cap Screw</p>	<ul style="list-style-type: none"> <li>• Fasten Angle Bracket to Framed Corner Post</li> <li>• Fasten Batten to Batten Stud Post</li> <li>• Fasten Batten to Front of Framed Stud Post</li> <li>• Fasten Batten to Door Frame Header</li> </ul>
FABFAS625T		<p>1/4"-20x5/8" Low Head Socket Cap Screw</p>	<ul style="list-style-type: none"> <li>• Fasten Angle Bracket to Floor Track and Head Track</li> <li>• Fasten Batten to Back of Framed Stud Post</li> <li>• Fasten Batten to Framed Corner Post</li> </ul>
FABFAS1500T		<p>1/4"-20x1 1/2" Flat Head Socket Cap Screw</p>	<ul style="list-style-type: none"> <li>• Fasten Door Jamb to Stud Post</li> </ul>
FABBKT		<p>Angle Bracket Connection</p>	<ul style="list-style-type: none"> <li>• Connect Corners, Studs, Wall Starters to Floor Track and Head Track</li> <li>• Connect Horizontal Framing to Vertical Framing</li> </ul>
FABGSKPN		<p>Head Track Gasket</p>	<ul style="list-style-type: none"> <li>• Gaskets Wall at Head Track</li> </ul>

## Installation of Head Track

The first component to be installed is the 2.4" straight head track (FABAEANHT). Before mounting the head track to the ceiling grid or existing structure install the head track gasket (FABGSKPN) by inserting the gasket into the "T" groove in the head track. A 3/8" x 1/4" neoprene gasket (FABGSKNEO3/8) should be applied to one side of the center flange to help seal the head track-ceiling connection. The head track is to be installed directly beneath the ceiling grid as per the layout of the particular project. At 3-way connections, 4-way connections or wall starters, the head track should abut the perpendicular head track or existing wall.

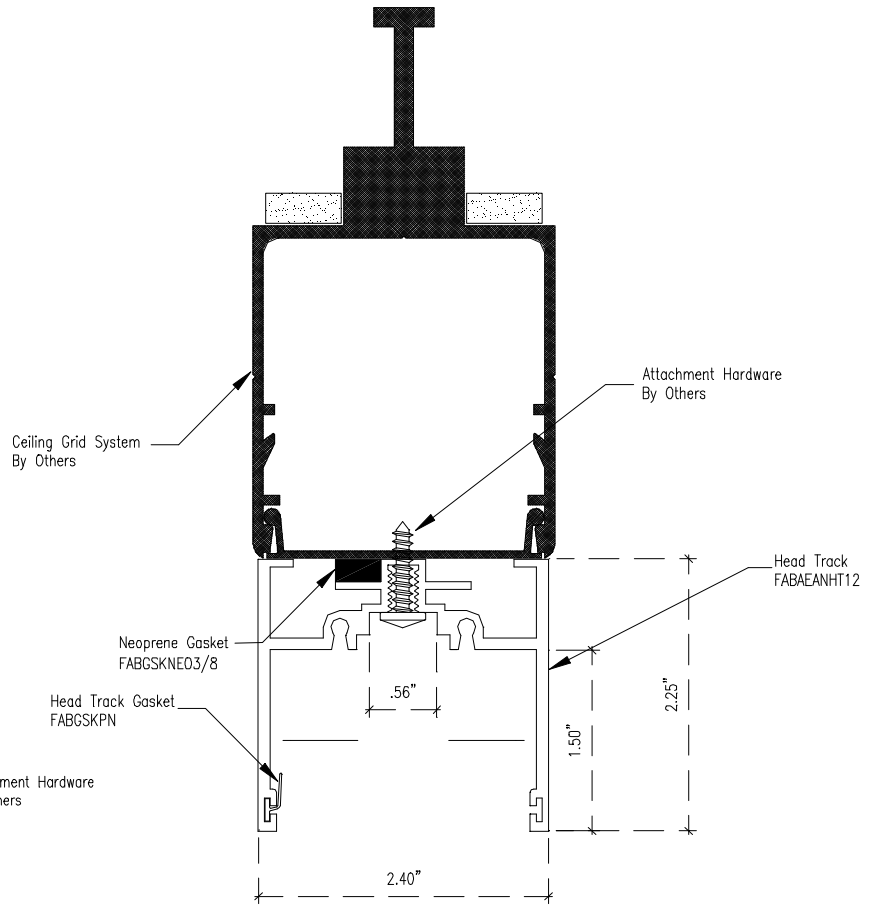
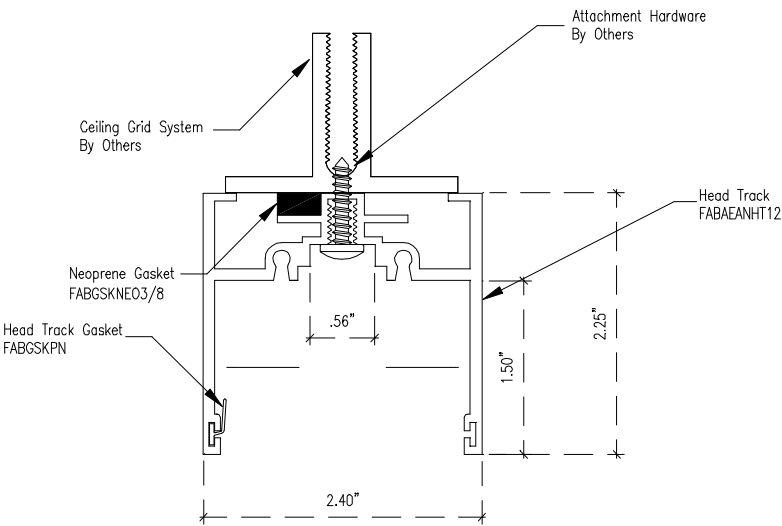

## Head Track at Corners

The head track (FABAEANHT) is to be miter cut at 45° in the field by the installation team to create corners.

## Installation of Floor Track

After the head track is installed, the floor track (FABAEANFT) is to be secured to the floor. The floor track is to be laid at all areas except at door openings, framed openings, and equipment bulkheads. It is very important that the centerline of the floor track is directly beneath the centerline of the head track, especially at doors, to assure

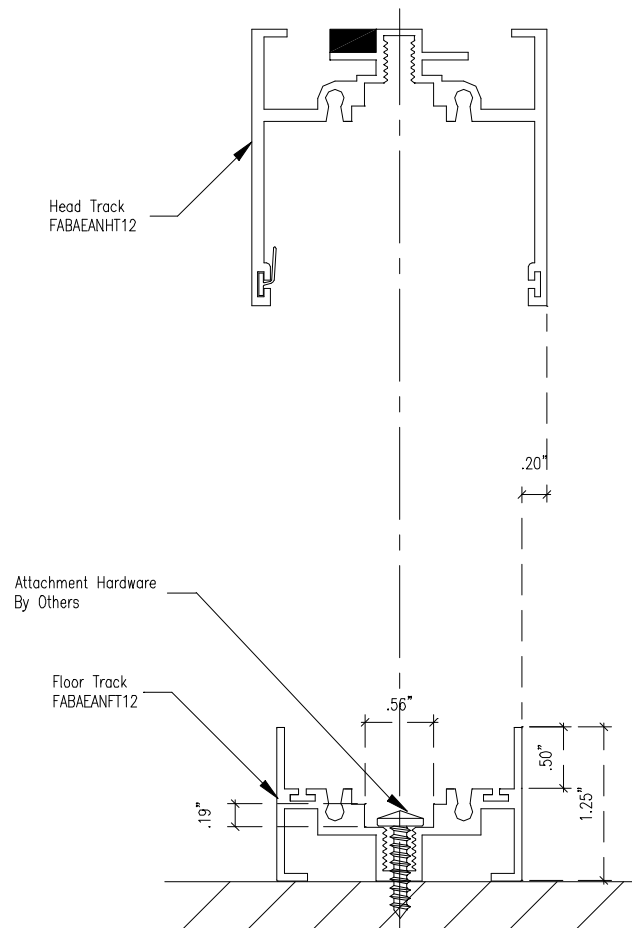

proper operation. For this a plumb bob tool should be utilized.

Attachment at approximately 24" to 36" on center is usually adequate. It should be noted here that if hardware is selected which will extend above the track in the floor track, the connection points are to avoid the grid lines, which typically can be accomplished by checking the ceiling grid lines overhead.

### Floor Track at Corners

The floor track (FABAEANFT) is to be miter cut at 45° in the field by the installation team to create corners.

An actual piece of corner post assembly can be helpful in aligning the floor track pieces. If preferred, the full height corner post assemblies can be installed at this time, as described in *Installation of Corners*.

### Floor Track at Door Openings

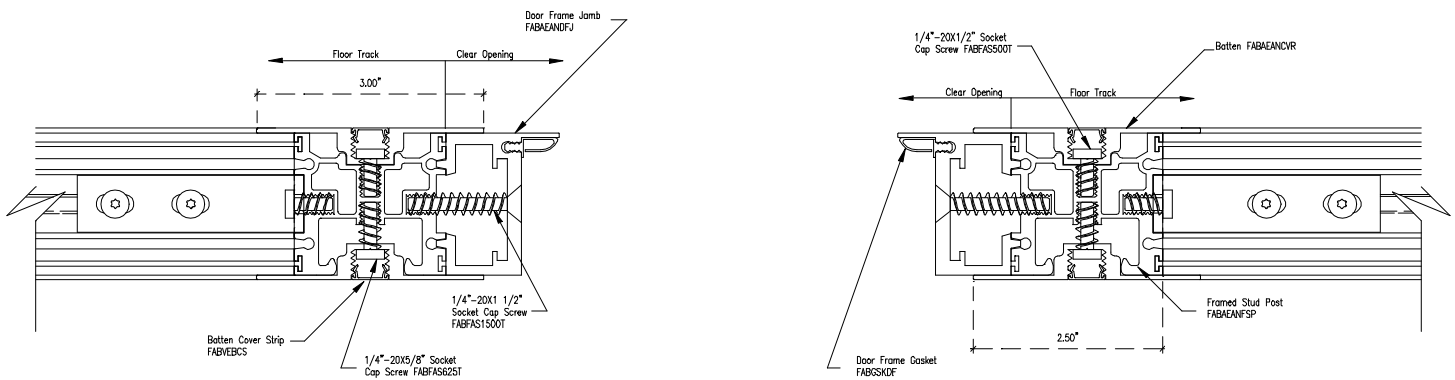

An opening must be left in the floor track layout for door openings. The side door jambs (FABAEANDFJ) mount directly to a framed stud post (FABAEANFSP) to form an assembly. The actual door jambs are notched at the bottom and extend to the floor. The framed stud post extends down into the floor track and attaches to it via an angle bracket (FABBKT). Screw the angle bracket to the framed stud post with two 1/4"-20 x 1/2" socket head fasteners (FABFAS500T) and then to the floor track with two 1/4"-20 x 5/8" socket head fasteners (FABFAS625T) utilizing a T-27 torx driver. The floor track position receives one angle bracket and the head track position receives two angle brackets.

In order to determine the opening size in the floor track for the door(s), add 2" to the nominal door width. For standard Porta-Fab door sizes, these would be as follows:

Nominal Size	Nominal Door Leaf	Single or Double	Floor Track Opening	Centerline of Stud
2070	24" x 84"	Single	26"	28"
3070	36" x 84"	Single	38"	40"
6070	72" x 84"	Double	74"	76"

For additional information on installing FabLine door systems, see the *FabLine Door Installation Instructions* manual for complete details.



## Floor Track at Wall Ends and Framed Openings

Wall ends are handled similar to door openings for floor track installation. The framed stud post extends down into the floor track (FABAEANFT) and attaches to it with an angle bracket (FABBKT). The framed stud post shall be secured 1/2" away from the termination of the floor track to allow enough space for the connection of the wall end cap. The floor track shall terminate at the end of the wall end cap.

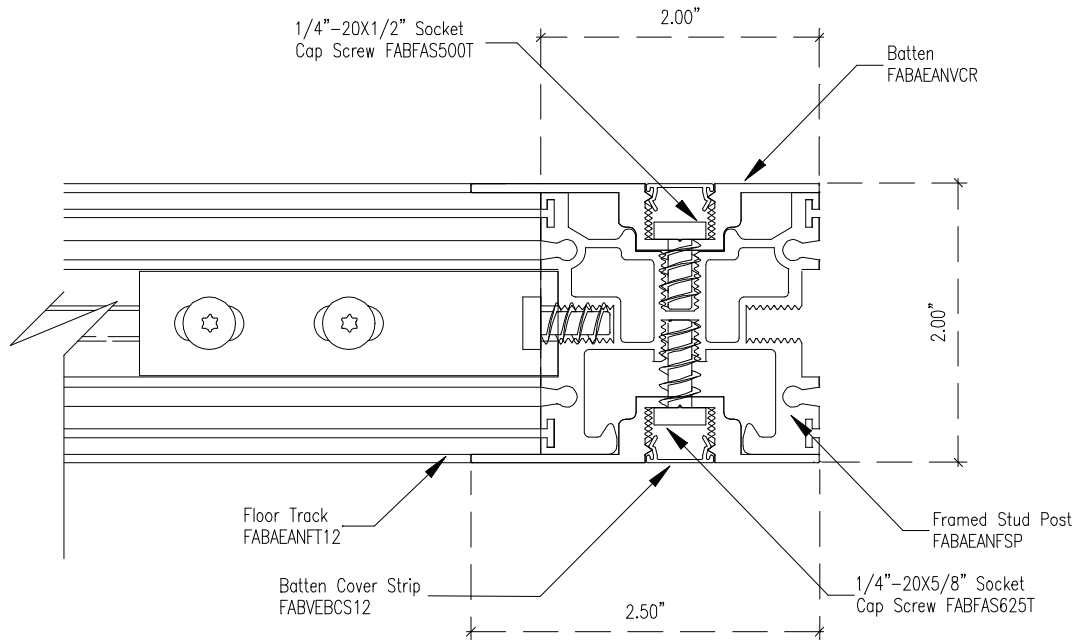
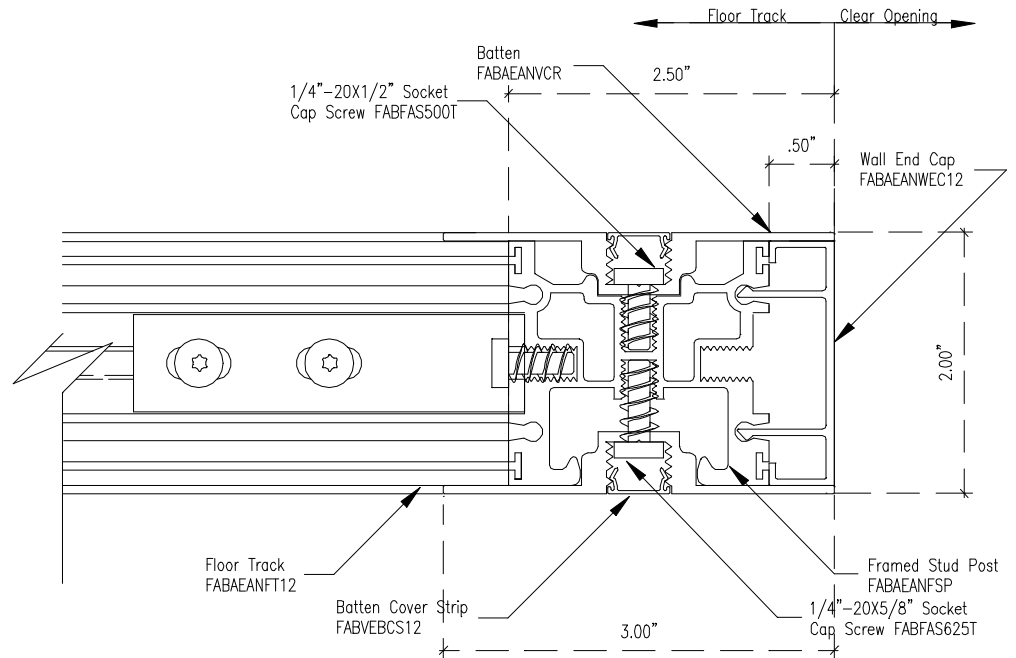

Framed openings for sliding doors are handled as wall end caps for floor track installation. The corresponding post assembly extends into the floor track (FABAEANFT) and is attached to the floor track, with one angle bracket (FABBKT).

At framed openings, the framed stud post shall utilize two half battens (FABAEANBWC). The floor track shall terminate at the end of the framed stud post.

## Installation of Corners

The corner post assembly is ready to install after the head track and floor track are in place. There are two types of corner posts which may be supplied with the project: a framed corner post (FABAEANFCP) or a batten corner post (FABAEANBCP). If the height of the corner post needs to be modified, subtract 2 1/4" from the inside floor to ceiling (e.g. 120" floor to ceiling clear height – corner post height should be 117 3/4" tall) and cut at the unnotched end. For the battens and batten cover strips, subtract 2 3/4" from the inside floor to ceiling.

With the *framed corner post*, the corner post, battens, and cover strips should be cut to the correct height in the field by the installation crew. The framed corner post (FABAEANFCP) is notched at one end which allows it to install into the floor track extrusion. Slip the unnotched end of the corner post into the corner made in the head track and lift it to the top of the head track. Position the notched lower end of the corner post assembly so that recessed track in the corner aligns with that of the floor track and pull the corner down to the floor. The top should still be contained in the head track creating a rigid vertical member.

Next, align the angle bracket (FABBKT) into the recessed track of the corner post and use two 1/4"-20 x 1/2" socket cap screws (FABFAS500T) to attach the angle bracket to the corner post. Use two 1/4"-20" x 5/8" socket cap screws (FABFAS625T) and secure the angle bracket to the floor track. Perform this action for both pieces of floor track creating the corner. Repeat this step when attaching the angle bracket at the head track location, except do not fasten the angle bracket to the corner post. This will allow the head track to float up to 3/4" for any deflection room, if needed.

Next install the battens (FABAEANCVR) in the same manner as the framed corner post so the battens insert into the

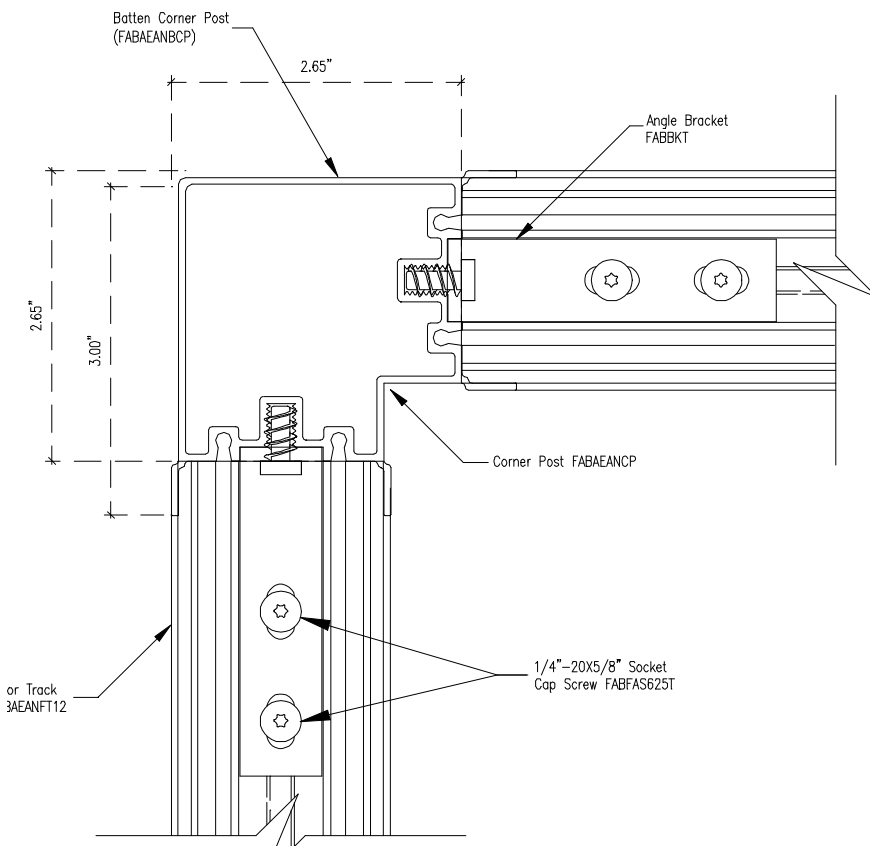
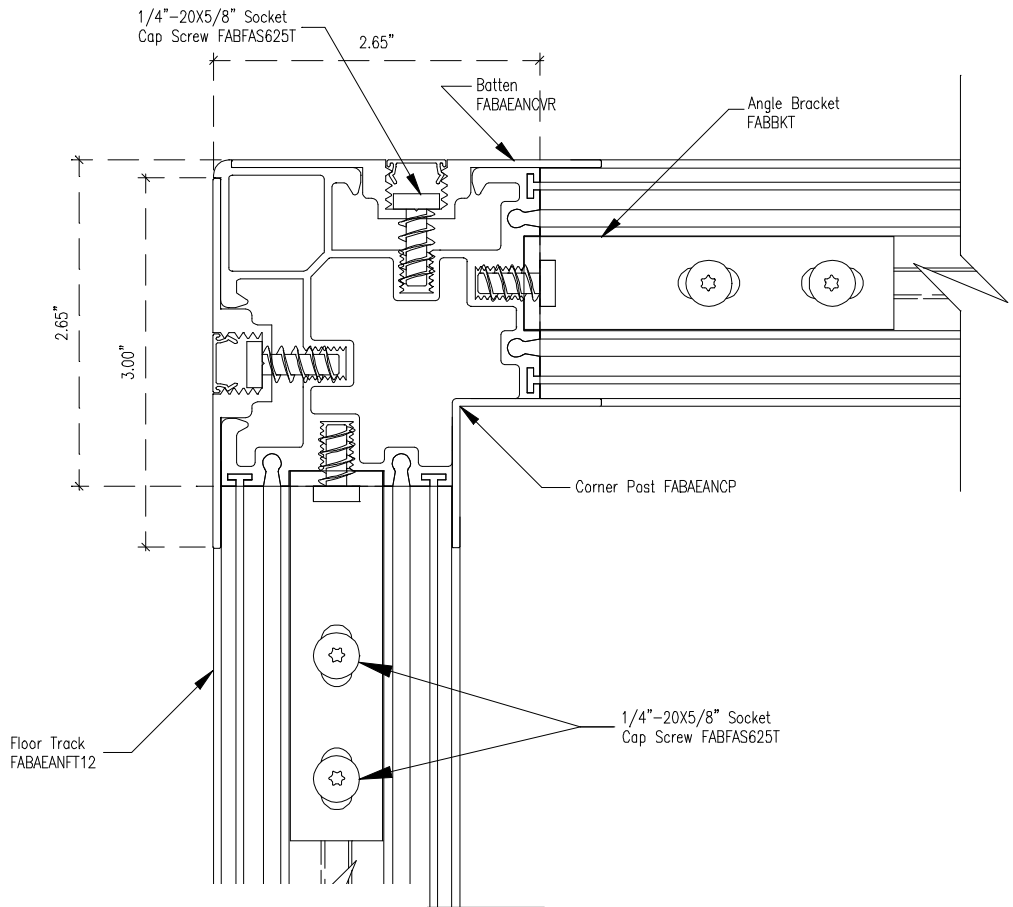

groove on the framed corner post. Fasten the two together with 1/4"-20 x 5/8" socket head cap screws tightening with a T-27 torx driver. Install the batten cover strips into the battens.

With the *batten corner post*, the corner post should be cut to the correct height in the field by the installation crew. The batten corner post (FABAEANBCP) is notched at one end which allows it to install into the floor track extrusion. Slip the unnotched end of the corner post into the corner made in the head track and lift it to the top of the head track. Position the notched lower end of the corner post assembly so that recessed track in the corner

aligns with that of the floor track and pull the corner down to the floor. The top should still be contained in the head track creating a rigid vertical member.

Next, align the angle bracket (FABBKT) into the recessed track of the corner post and use two 1/4"-20 x 1/2" socket cap screws (FABFAS500T) to attach the angle bracket to the corner post. Use two 1/4"-20" x 5/8" socket cap screws (FABFAS625T) and secure the angle bracket to the floor track. Perform this action for both pieces of floor track creating the corner. Repeat this step when attaching the angle bracket at the head track location, except do not fasten the angle bracket to the corner post. This will allow the head track to float up to 3/4" for any deflection room, if needed.

## Installation of Wall Starts on Existing Walls

A wall starter is defined as an abutment of the Porta-Fab wall system to any other surface, such as an existing wall.

The wall starter is made by fastening a piece of floor track (FABAEANFT) to the adjoining surface. The floor track to be utilized as a wall starter should be cut to 2 3/4" less than the floor to ceiling measurement. (e.g. 120" floor to ceiling clear height – wall starter height should be 117 1/4" tall). This will allow the wall starter to extend into the head track, maintaining space for deflection of the ceiling grid or substructure above.

Install the wall starter by lifting the floor track into the head track above and pull the floor track used as a wall starter down so that the bottom of the wall starter extends down onto the top of the floor track. An angle bracket (FABBKT) should be aligned into the tracks of the floor track and wall starter. The angle bracket is to be fastened to the wall starter with two 1/4"-20 x 5/8" socket cap screws and to the floor track with two 1/4"-20" x 5/8" socket cap screws utilizing a T-27 torx driver prior to fastening the floor track to the existing wall surface. Repeat this step when attaching the angle bracket at the head track location.

The wall starter should now be attached to the existing surface with fasteners depending on the particular surface, which is not provided by Porta-Fab. Utilize the same guidelines in determining the size of this fastener as discussed in the section on page 3, *Fasteners Not Provided By Porta-Fab*.

## Installation of Wall End Caps

A wall end cap is the termination of the Porta-Fab wall system in an open area, such as a "wing wall." At this location, the head track and the floor track are to be extended to the stopping point.

First, install the framed stud post (FABAEANFSP) by inserting one end into the head track and pulling it down into the floor track. Next, align the angle brackets (FABBKT) into the

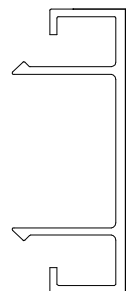
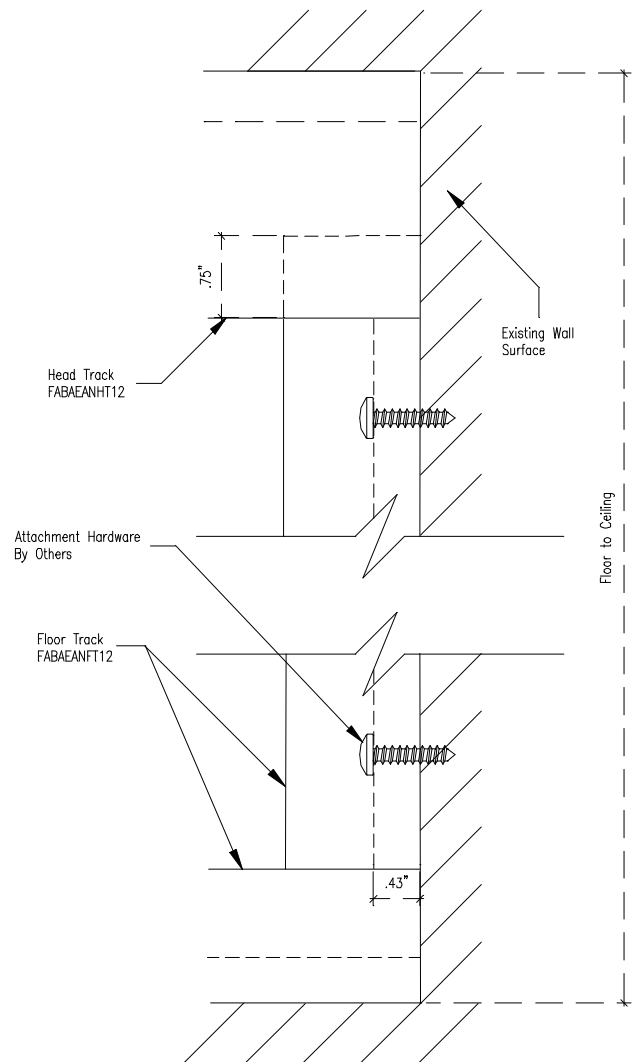

recessed track of the stud post and use two 1/4"-20 x 1/2" socket cap screws (FABFAS500T) to attach the angle bracket to the stud post. Use two 1/4"-20" x 5/8" socket cap screws (FABFAS625T) and secure the angle bracket connection to the floor track. Repeat this step when attaching the angle bracket at the head track location.

Next, install the battens (FABAEANCVR) on both sides of the stud post. This is done by inserting one end into the head track and pulling it down until the bottom of the batten abuts to the leg of the floor track providing a flush abutment between the two components. Fasten the two together with either the 1/4"-20 x 1/2" or 1/4"-20 x

5/8" socket head cap screws depending on which side of the stud post you are installing the batten. Tighten with a T-27 torx driver until batten is secured to the stud post.

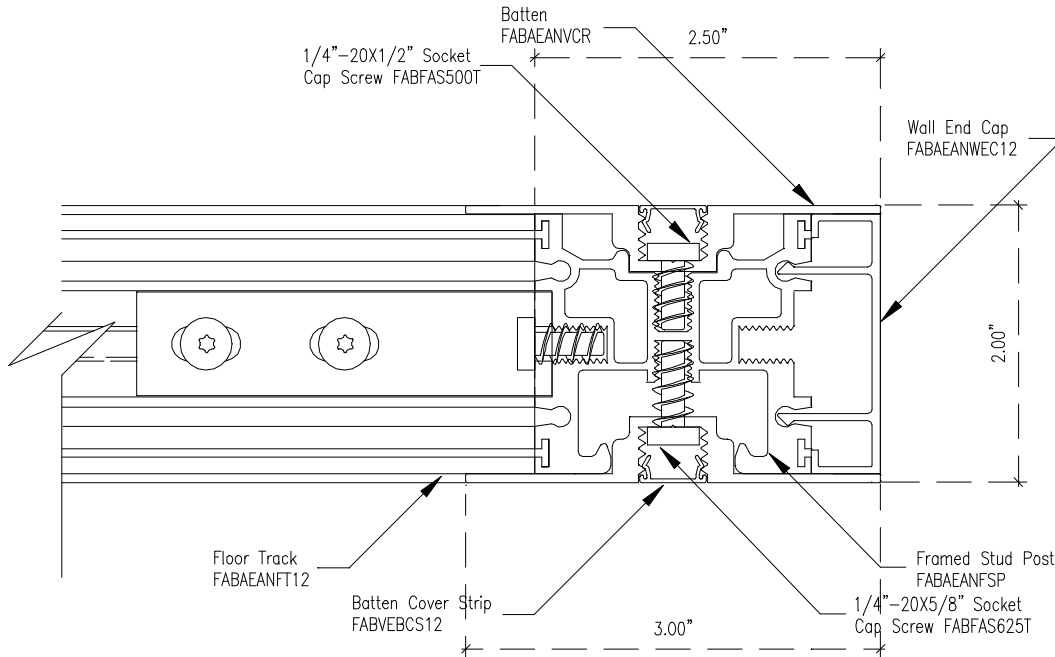

To finish the exposed end of the post assembly, measure and cut to length a wall end cap (FABAEANWEC). This extrusion then snaps into framed stud post, and after installed, is flush with the edges of the battens. Finally, install the batten cover strips into the battens.

### Installation of Panels and Preglazed Panels

Before installing a panel, peel back the protective film on both surfaces of the panel around all four edges. By leaving the majority of the film in place until final clean-up, there is extra protection against damage to the panels.

To install a panel, lift one end up into the head track until it clears the floor track. Position the panel over the floor track and pull it down into the floor track. Panels are typically installed on the same gridlines as the cleanroom ceiling grid overhead or access floor below, which can act as a guide during installation. A gap of 2 1/4" is to be left between panels, which will be filled by the batten stud assembly.

Panels at the end of a straight run may require to be cut down to width. In these instances, please refer to the panel dimension chart for correct panel widths from various extrusion connections. Mark and cut the panel with a circular saw while the plastic protective film remains intact.

## PANEL DIMENSION FOR VARIOUS WALL CONDITIONS

DIMENSIONS SHOWN INCLUDE THE STANDARD 45 3/4" WIDE PANEL

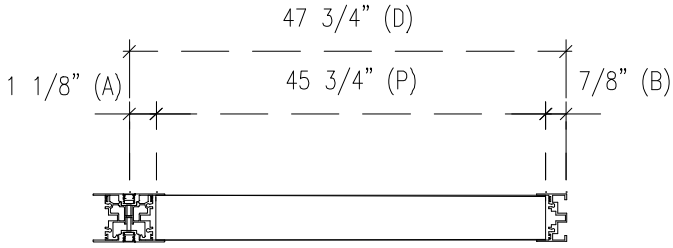

Stud to Wall Starter Dimension  
 $P=D-(A+B)$

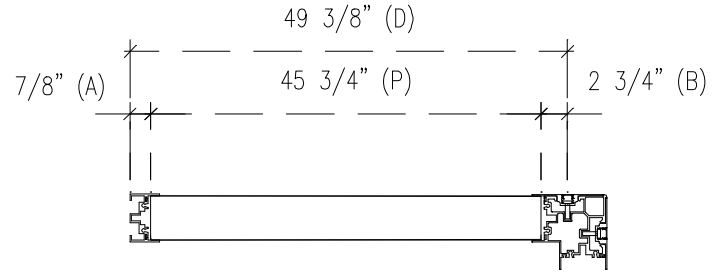

Wall Starter to Corner Dimension  
 $P=D-(A+B)$

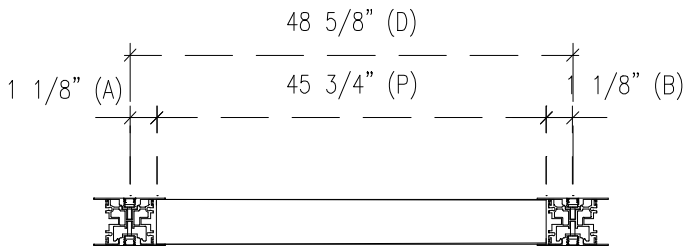

Stud to Stud Dimension  
 $P=D-(A+B)$

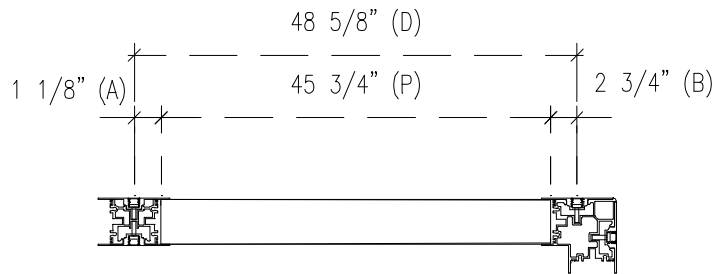

Stud to Corner Dimension  
 $P=D-(A+B)$

### Installation of Batten Stud

The gap between the panels is to be closed off with the batten stud set, which also ties the panels together creating a rigid wall system. If the height of the batten stud post and batten needs to be modified, subtract 2 1/4" from the inside floor to ceiling (e.g. 120" floor to ceiling clear height – batten stud post height should be 117 3/4" tall).

First, install the batten stud post (FABAEANBSP) by inserting one end into the head track between two panels, and pulling it down until the bottom is tight against the upper edge of the floor track. Next, install the batten (FABAEANCVR) in the same manner as the batten stud post so that the batten inserts into

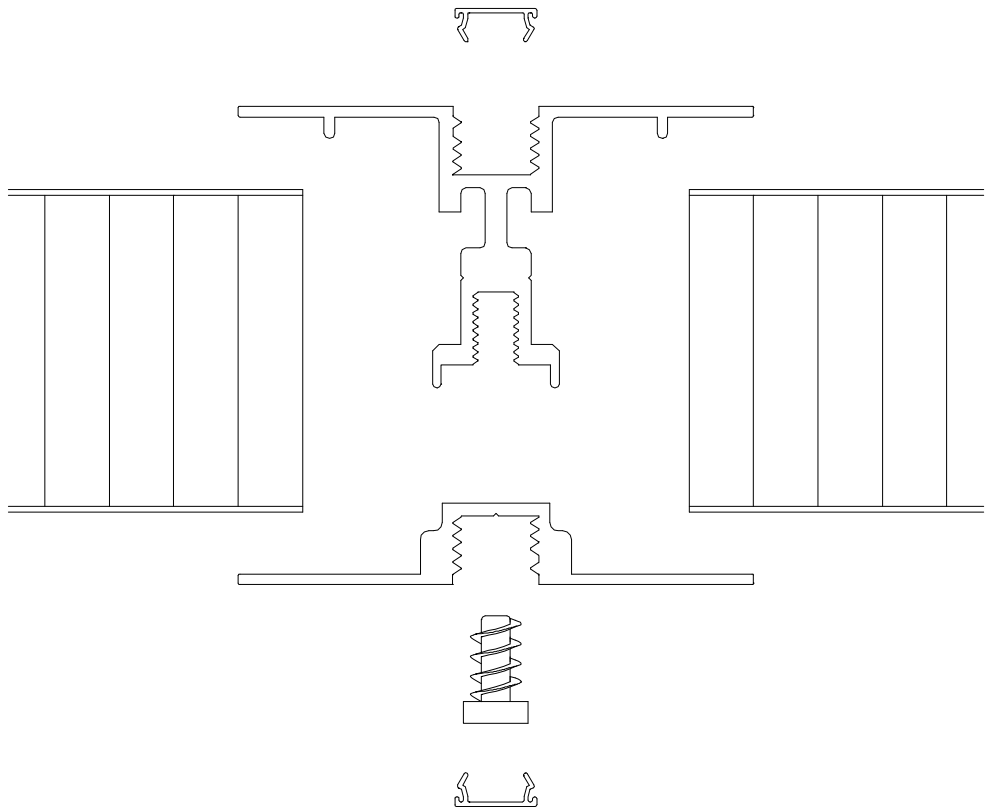

the groove on the batten stud post. Fasten the two together with 1/4"-20 x 1/2" socket head cap screws tightening with a T-27 torx driver until battens are gripping the panel firmly. Install the batten cover strips into the batten and batten stud post.

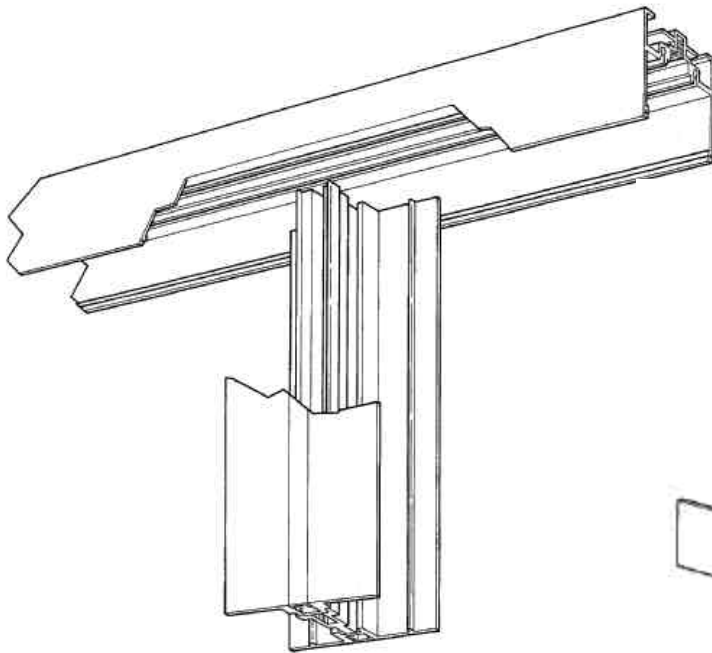
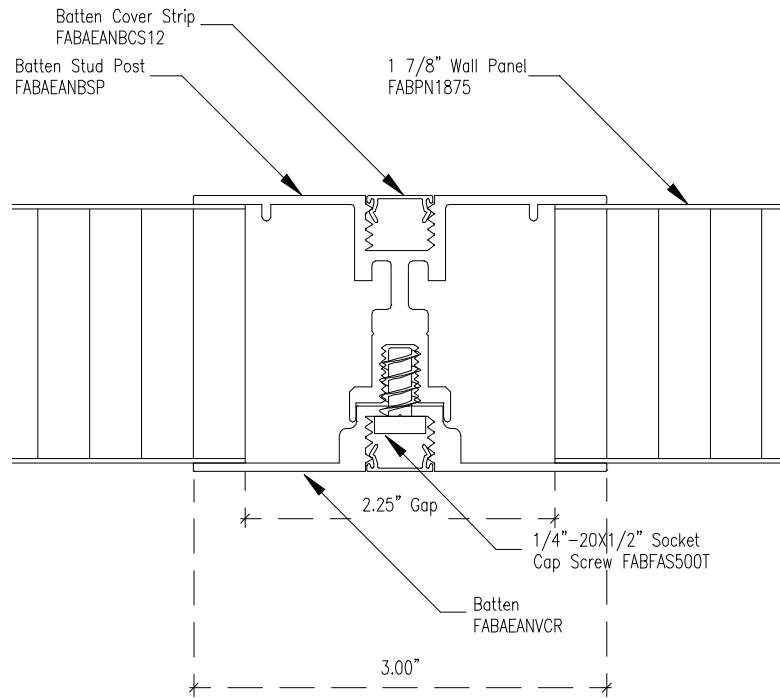

Batten Stud at Head Track

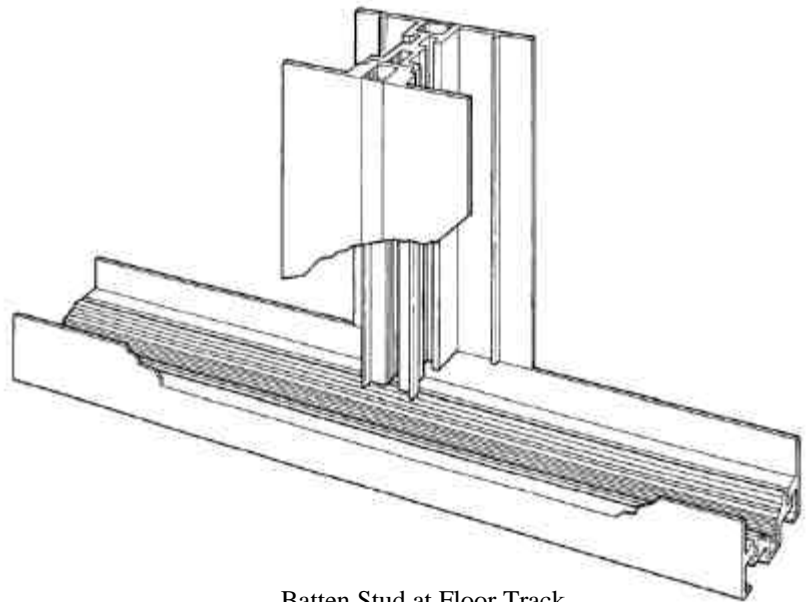

Batten Stud at Floor Track

## Installation of Tee-Intersections

A tee intersection is a three way intersection of the Porta-Fab wall system. In order to utilize the tee-intersection batten, a panel joint must occur at this location on the wall which extends through the intersection. Even if this is not on the scheduled grid line, a joint can be inserted by cutting the panel on each side of the added joint.

To create a tee intersection, replace the batten with the wall starter (FABAEANWS). The flanges built into this batten act to "start" the abutting wall panel.

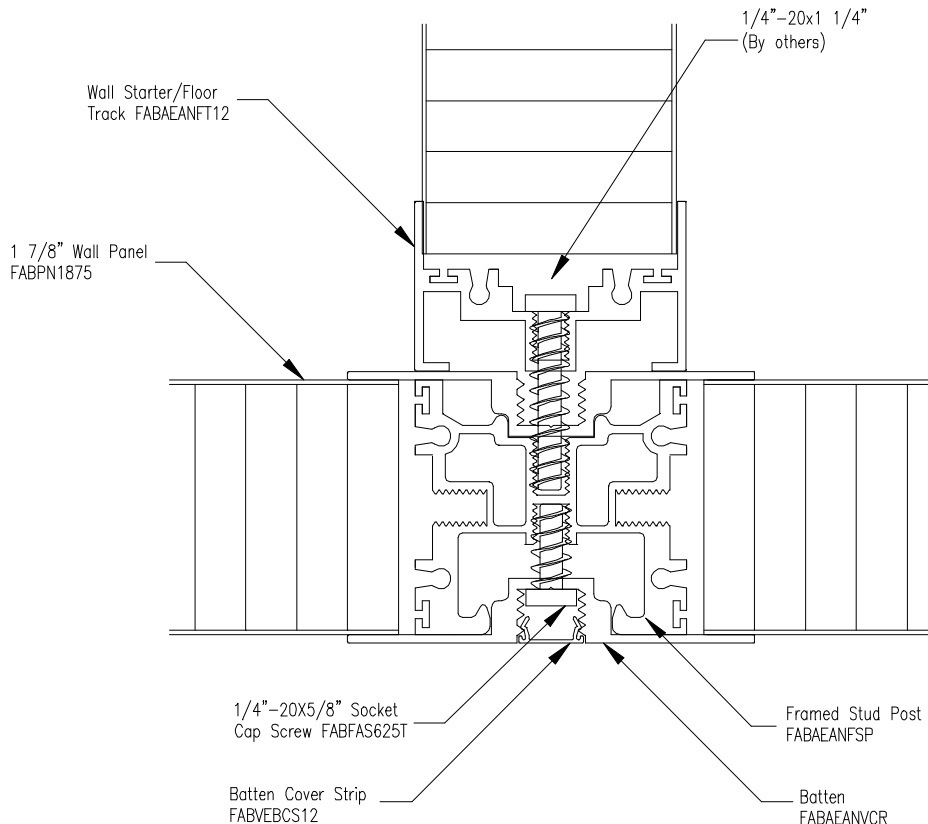
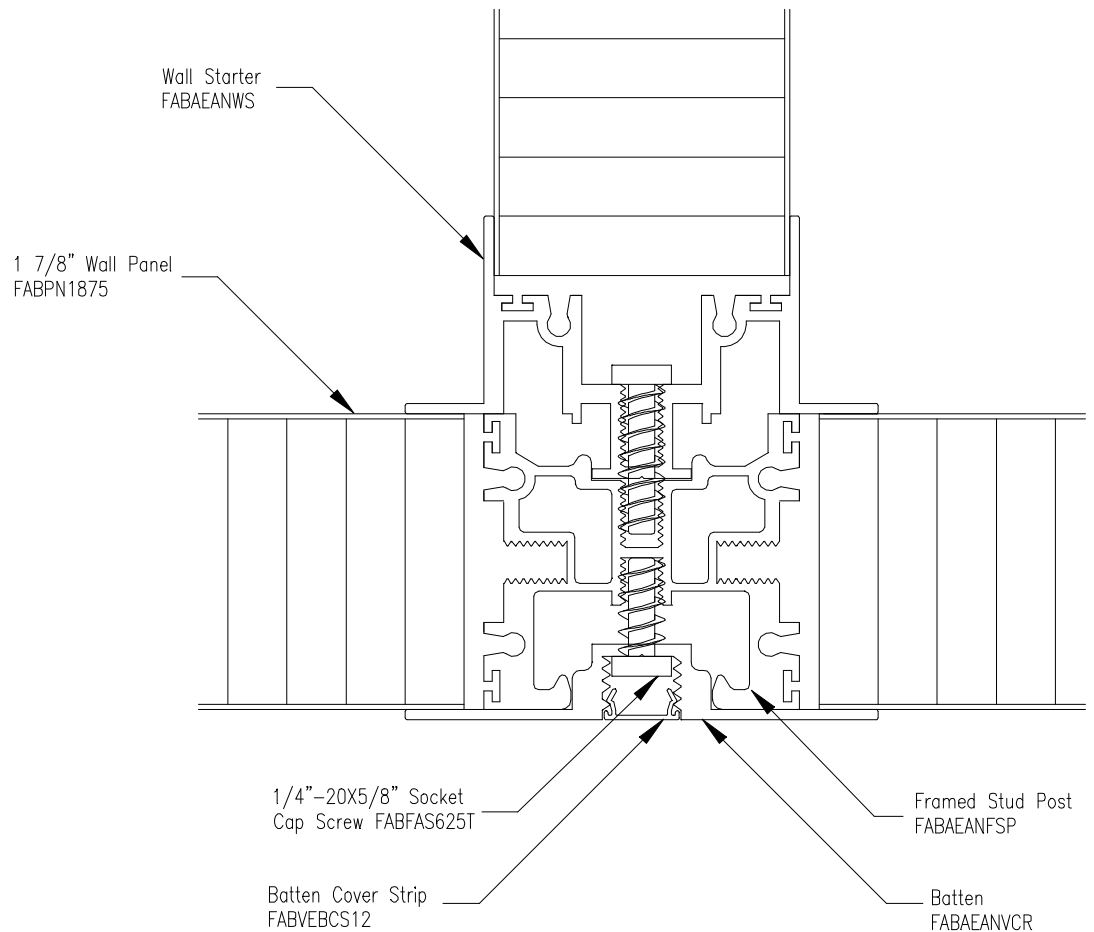

A floor track extrusion (FABAEANFT) may also be used as a wall starter. To attach to a panel joint, attach the floor track to the batten. The floor track should align with the top leg of the horizontal floor track.

The floor track extrusion can also be used to start a three-way connection directly off a wall panel.

## Final Inspection and Wipe Down

Since components of the Porta-Fab wall system are interchangeable, it may be desirable to utilize Framed components in an installation which is mostly Batten. Typically this would be for openings in the wall system, such as sliding door units, and bulkhead equipment openings in the wall. Please see the installation instructions on the Framed Wall System for further information on these topics.

Prior to completing the installation, a final inspection and wipe-down should take place. First, remove the plastic protective film from the panels by pulling them off. It may be desirable to leave the plastic film in place until after equipment is placed in the room to provide added protection to the panels.

Wipe the panels and extrusions with an approved cleanroom alcohol wipe. If any chemicals are to be utilized, spot check with extra materials prior to use to insure that the finish of the wall system is not damaged.