

- GENERAL NOTES:
- 1) ALUMINUM FRAMING EXTRUSIONS HAVE A MILL FINISH.
 - 2) FIXED WINDOWS TO INCLUDE CLEAR TEMPERED GLAZING.
 - 3) UNIT INCLUDES FACTORY INSTALLED INTERNAL ROOF WITH PERIMETER GUTTER. (NO FLOORING PROVIDED).
 - 4) UNIT PROVIDED FACTORY ASSEMBLED. (NO FLOORING PROVIDED).

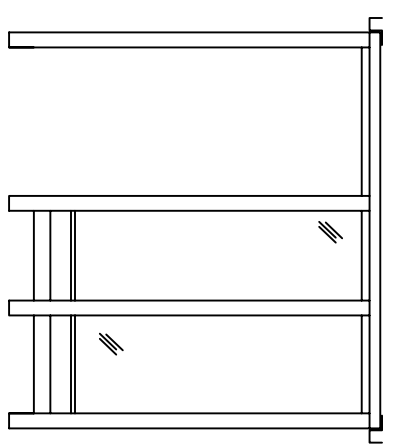
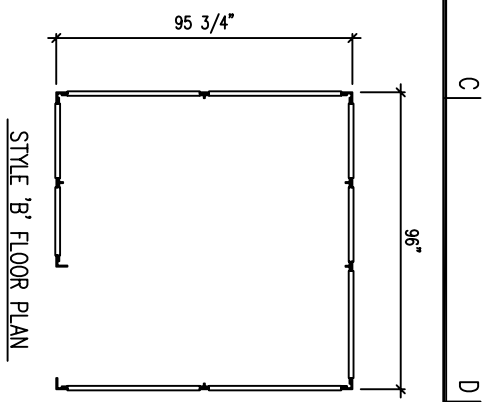
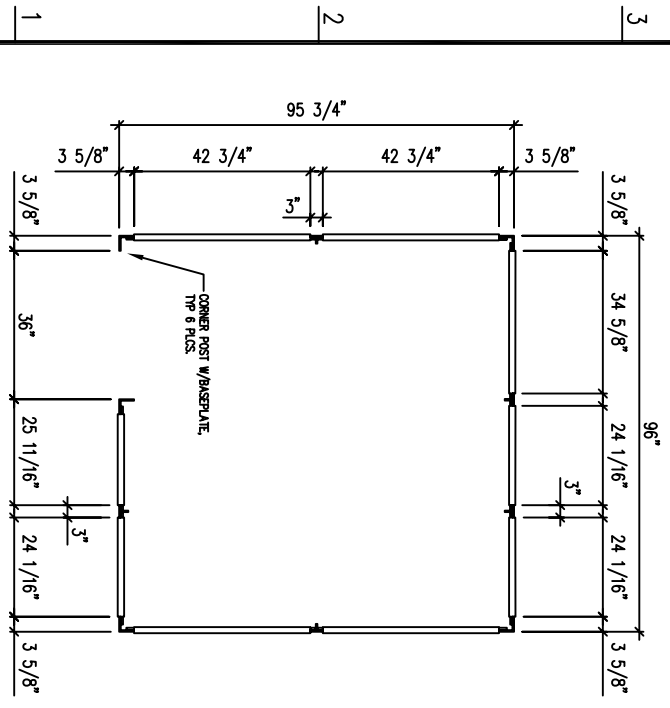

ORDER NO.	DRAWN BY:	DATE:	PRE-ASSEMBLED	P.O.	PORTAFAB CORPORATION 18000 CHESTERFIELD AIRPORT ROAD, CHESTERFIELD, MO 63005 email: engineering@portafab.com (800) 325-3781	REV.	DESCRIPTION	DATE
	CD		PANEL HEIGHT: N/A			8x8 SHELTER		
SHEET NO.	CHECKED BY:	SHIP DATE:	PANEL FINISH: PEARL (#750) FRP	P.O.	These documents were developed by PORTAFAB Corporation. The information contained herein is the property of PORTAFAB Corporation. They are not to be copied or otherwise used without the express written permission of PORTAFAB Corporation.			
	1 OF 1	SCALE: N/A	PANEL CONSTRUCTION:					

SUPPLIER MAKES NO REPRESENTATION THAT THE BUILDING OR COMPONENT DEPICTED HEREIN COMPLIES WITH APPLICABLE CODES OR ORDINANCES. PURCHASER SHOULD VERIFY COMPLIANCE WITH SUCH CODES AND ORDINANCES.